

SONOREX
SONOPULS

High-power ultrasound
in laboratories



Cleaning
Degassing
Emulsifying
Cell disruption
Homogenizing
Sample preparation



BANDELIN

60 years of experience in ultrasound

Recommendations on ultrasonic cleaning

How does ultrasound work

Vibrations at frequencies exceeding 18 kHz (18,000 vibrations per second) are called ultrasound. As a result of these vibrations millions of smallest vacuum bubbles are formed in liquids. They implode during the high pressure phase and create highly effective pressure waves. This process is called cavitation and causes the removal of dirt particles from the objects to be cleaned. Lower frequencies of approx. 20 kHz which are applicable in cell disruption, produce bubbles with larger diameters and stronger pressure waves than higher frequencies of approx. 35 kHz which are used for intense but gentle cleaning. The HF generator converts the mains frequency into the corresponding frequency of the ultrasonic bath. This frequency is transformed into mechanical vibrations by transducers underneath the tank. Ultrasound is transmitted to the liquid in the bath. All ultrasonic baths (except DK-units) use **SweepTec®** – a special frequency modulation around an optimally fixed operating point. A very homogeneous and even ultrasonic field is achieved.

Advantages of ultrasonic cleaning

Ultrasonic cavitation removes dirt rapidly from items, thoroughly and deep from pores, even from difficult to reach places such as cavities or holes. Ultrasound cleans only in a few minutes and exceeds in its efficiency other cleaning methods. Ultrasonic cleaning is also gentle because even slight damage like scratches are eliminated.

Advantages in process engineering and sonochemistry

Cavitation not only can be used for various purposes, but a very fine emulsion of oil and water can be produced by ultrasonic application. Compared to other manufacturing processes this emulsion is more stable. For sonochemical processes in an ultrasonic bath, the reaction vessel should have a thin bottom. Thus, the ultrasonic energy is radiated directly and effectively into the reaction vessel.

How to select the proper unit

SONOREX ultrasonic baths work with the intense cleaning frequency of 35 kHz. Size and number of objects to be cleaned determine size of the ultrasonic bath. When selecting the unit, dimensions of the accessories, e. g. baskets have to be considered. To avoid overloading, it is recommended to choose a slightly larger unit. This also allows additional applications at a later stage.

Should an ultrasonic unit have a heating

Warm cleaning solutions reduce the cleaning time; dirt is removed faster. Units with heaters are the preferred choice for cleaning processes in laboratories. Disinfectant solutions must not be warmed-up because protein coagulation starts at a temperature of 40 °C (104° F) and this poses an obstacle for some cleaning and all disinfection processes. Therefore, units without heaters are recommended for these applications.

What kind of accessories should be used

Objects to be cleaned and reaction vessels must not be placed on the tank bottom. Insert baskets avoid scratching either the parts to be cleaned or the tank bottom. Beakers are placed into positioning lids and are used for cleaning of small objects or when working with aggressive solutions.

Which cleaning agents are appropriate

TICKOPUR and STAMMOPUR cleaning and disinfectant agents are especially developed for application in SONOREX ultrasonic baths. Water without any cleaning agent does not clean. Household detergents as well as DI-water should never be used. It is necessary to use plastic insert tubs, when working with acids or removing acid residues. Flammable liquids must not be used directly in the ultrasonic tank.

BANDELIN electronic, a family-owned mid-sized company, is located in the capital of Germany – Berlin. The company has 60 years of experience in ultrasound technology. Development and manufacture of ultrasonic devices and disinfectant and cleaning agents are carried out in Berlin. A high vertical range of manufacture, modern production lines and a high-motivated staff guarantee a high quality of the products. The customers can buy everything from one-hand. Ultrasonic devices are in use in nearly all branches like industry, maintenance, service, medical, pharmaceutical and dental fields as well as laboratories.

The brand names SONOREX, SONOPULS and SONOMIC are equated with ultrasound from experts.

The most important product groups are:

- SONOREX – Ultrasonic cleaning devices
- SONOPULS – Ultrasonic homogenisers
- SONOREX – Ultrasonic reactors
- SONOMIC – Ultrasonic cleaning device for rinseable keyhole surgery instruments
- ultraPuls – Ultrasonic therapy devices
- STAMMOPUR and TICKOPUR – Disinfection and cleaning agents

All products are CE marked, also as medical devices according to Medical Device Directive (MDD), and classified to UMDNS™, too.



Overview on SONOREX ultrasonic baths



Features	Series	DIGITEC DT...	SUPER RK ...	DIGITAL 10 P DK ...
Tank volume (litres)		0.9 – 90.0	0.9 – 90.0	3.0 – 28.0
Control elements		push-buttons	turning knobs	push-buttons
Time setting (min)		1 – 30, continuous operation [∞]	1 – 15, continuous operation [∞]	1 – 99, continuous operation [∞]
Safety shut-down		after 12 hours	no	no
Heating		optional, version "H"	optional, H-Version	yes
Heating, thermostatically adjustable		20 – 80 °C	30 – 80 °C RK 31 H: 65 °C fixed	20 – 80 °C
Excess temperature signal		yes	no	no
Protection against delay in boiling		yes, optionally switch-on	no	no
Setting accuracy of bath temperature		± 3.5 K	± 5 K	± 1 K
Thickness of stainless steel tank material version "C"		0.8 mm. AISI 314 2 mm. AISI 316 Ti	0.8 mm. AISI 304 2 mm. AISI 316 Ti	0.8 mm. AISI 304 -
Marking of filling level for safe dosage		yes	yes	yes
Hard chromium-plated		DT 102 H / H-RC	RK 102 H	no
Warranty period (years)		2, DT 102 H = 3	2, RK 102 H = 3	2
One-piece drain, welded		yes, from DT 102 H	yes, from RK 102 H	yes, from DK 156 BP
Liquid protection		protected against spray	drip-proof	protected against spray
Degree of protection		IP 33	IP 32	IP 33
Ultrasonic frequency (kHz)		35	35	35
Sweep – SweepTec®		yes	yes	no
Power setting		no	no	yes
PCT-transducers (PCT = lead circonate titanate)		yes	yes	yes
Fast degassing		yes	no	yes
Mains supply 230 V~, 50/60 Hz		yes	yes	yes
alternatively: mains supply 115 V~, 50/60 Hz		yes	yes	no
Data memory		no type H-RC: WINSONIC® software	no	10 programs
Interface		RS 232, type H-RC	no	no
PC software		yes	no	no
CE marked as medical device		yes, except for DT 1050 CH	yes, except for RK 1050 / CH	no

For units with larger volumes (SONOREX TECHNIK), see last page.

Digital high-power ultrasonic baths with fast degassing

Applications:

- Cleaning of technical glassware like burettes, pipettes, petri dishes and laboratory flasks
- disinfection and cleaning at the same time
- Degassing of beer samples for analysis of alcohol contents, original worth, colour, pH value
- Degassing of food samples from cans for analysis of stannous contents
- Extraction of quaternary ammonium compounds (QAC) of wood
- Extraction of herbs samples for determination of aflatoxines (causing mold decay on food)
- Extraction of soil samples for determination of hydrocarbons
- Test method for freeze-thaw resistance of concrete: CDF test – through sonication, loosely adhering scaled particles are removed from surface



Internal tank dimensions (l x w x d) mm	Capacity litres	Type	Code No.	External dimensions (l x w x h) mm	Drain ball valve	Ultrasonic peak output * W	HF output W _{eff}	Heating power W	Current consumption A	Weight net kg
190 x 85 x 60	0.9	DT 31	3200	205 x 100 x 170	-	240	30	-	0.2	1.8
		DT 31 H	3220							
150 x 140 x 100	1.8	DT 52	3205	175 x 165 x 230	-	240	60	-	0.3	2.6
		DT 52 H	3225							
240 x 140 x 100	3.0	DT 100	3210	260 x 160 x 250	-	320	80	-	0.4	3.4
		DT 100 H	3230		-	320	80	140	1.0	3.6
		DT 102 H	3235		G ¼	480	120	140	1.2	4.3
240 x 140 x 150	4.0	DT 103 H	3201	260 x 160 x 310	G ¼	560	140	200	1.5	4.6
Ø 240 x 130	5.6	DT 106	3270	Ø 265 x 270	G ¼	480	120	-	0.6	5.5
500 x 140 x 100	6.0	DT 156	3275	530 x 165 x 245	G ¼	640	160	-	0.7	6.1
500 x 140 x 150	9.0	DT 156 BH	3221	530 x 165 x 300	G ¼	860	215	600	3.6	7.3
300 x 150 x 150	5.5	DT 255	3215	325 x 175 x 295	G ¼	640	160	-	0.7	5.2
		DT 255 H	3240		G ¼	640	160	280	2.0	5.3
300 x 240 x 150	9.7	DT 510	3245	325 x 265 x 305	G ½	640	160	-	0.7	7.0
		DT 510 H	3206		G ½	640	160	400	2.5	7.6
300 x 240 x 200	13.0	DT 512 H	3226	325 x 265 x 350	G ½	860	215	400	2.7	8.0
325 x 300 x 150	13.5	DT 514	3250	355 x 325 x 305	G ½	860	215	-	1.0	8.2
		DT 514 H	3211		G ½	860	215	600	3.6	8.8
325 x 300 x 200	18.7	DT 514 BH	3216	355 x 325 x 385	G ½	860	215	600	3.6	9.8
500 x 300 x 200	28.0	DT 1028	3255	535 x 325 x 400	G ½	1200	300	-	1.4	14.3
		DT 1028 H	3231		G ½	1200	300	1300	7.0	14.7
500 x 300 x 300	45.0	DT 1028 CH	3266	540 x 340 x 500	G ½	1200	300	1450	7.7	23.7
600 x 500 x 300	90.0	DT 1050 CH	3271	640 x 540 x 530	G ½	2400	600	1950	11.1	37.0

*4 times higher than HF output caused by modulation of ultrasound – SweepTec®

High-power ultrasonic baths with infrared interface for process documentation

Applications:

- Degassing of liquids
- Acceleration of suspending processes
- Emulsifying
- Sample preparation for analysis

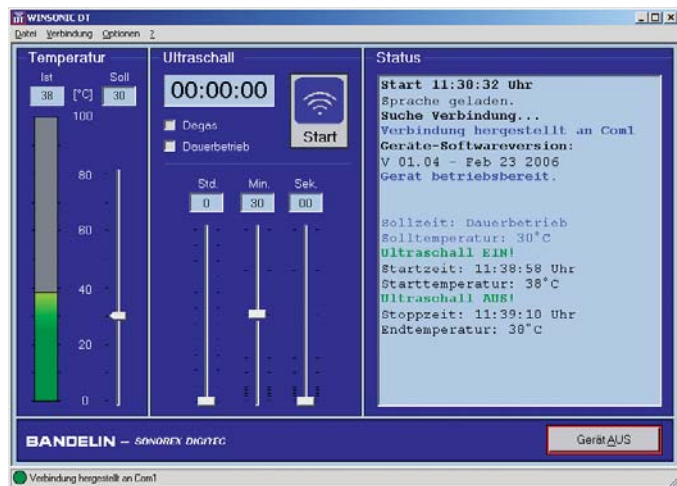

status screen



DT 102 H-RC with IR 1

WINSONIC® DT remote control

- The PC program is designed for operating systems MICROSOFT® WINDOWS®2000 and MICROSOFT® WINDOWS® XP in connection with the infrared adapter IR 1 allowing a comfortable operation and monitoring of DIGITEC DT ... RC ultrasonic baths.
- The status screen gives an updated overview on the working conditions.
- Start time and stop time as well as the respective bath temperature are automatically collected in log files. This way, a documentation of the process is possible for quality assurance.

WINSONIC® DT remote control consisting of:

software and infrared adapter IR 1

Code No. 3090

Interface for automation of laboratories

- RS 232 data interface to the laboratory PC allows processing of individual control tasks and integration into an automated laboratory line.
- Infrared adapter IR 1 is necessary for connection.
- Data log is disclosed and described in a detailed information for use.

Internal tank dimensions (l x w x d) mm	Capacity litres	Type	Code No.	External dimensions (l x w x h) mm	Drain ball valve	Ultrasonic peak output * W	HF output W _{eff}	Heating power W	Current consumption A	Weight net kg
240 x 140 x 100	3.0	DT 102 H-RC	3071	260 x 160 x 250	G ¼	480	120	140	1.2	4.3
300 x 150 x 150	5.5	DT 255 H-RC	3081	325 x 175 x 295	G ¼	640	160	280	2.0	5.3
300 x 240 x 150	9.7	DT 510 H-RC	3091	325 x 265 x 305	G ½	640	160	400	2.5	7.6
325 x 300 x 200	18.7	DT 514 BH-RC	3095	355 x 325 x 385	G ½	860	215	600	3.6	9.8

*4 times higher than HF output caused by modulation of ultrasound – SweepTec®

Analogous high-power ultrasonic baths - easy to operate

Applications:

- Cleaning of
 - technical glassware like burettes, pipettes, petri dishes and laboratory flasks
 - analysis sieves up to 400 mm diameter
 - medical instruments
 - metal parts of all kinds
 - electronic components
- Degassing of liquids to determine concentration
- Acceleration of suspending processes
- Disinfecting and cleaning at the same time
- Production of emulsions
- Preparation of samples for analysis, e. g. analysis of hair



Internal tank dimensions (l x w x d) mm	Capacity litres	Type	Code No.	External dimensions (l x w x h) mm	Drain ball valve	Ultrasonic peak output * W	HF output W _{eff}	Heating power W	Current consumption A	Weight net kg
190 × 85 × 60	0.9	RK 31	329	205 × 100 × 170	-	240	30	-	0.2	1.8
		RK 31 H	044		-	240	30	70	0.5	1.9
150 × 140 × 100	1.8	RK 52	311	175 × 165 × 225	-	240	60	-	0.3	2.6
		RK 52 H	164		-	240	60	140	0.9	2.9
240 × 140 × 100	3.0	RK 100	301	260 × 160 × 250	-	320	80	-	0.4	3.4
		RK 100 H	312		-	320	80	140	1.0	3.6
		RK 102 H	303		G ¼	480	120	140	1.2	4.3
240 × 140 × 150	4.0	RK 103 H	326	260 × 160 × 310	G ¼	560	140	200	1.5	4.3
∅ 240 × 130	5.6	RK 106	306	∅ 265 × 270	G ¼	480	120	-	0.6	5.5
500 × 140 × 100	6.0	RK 156	305	530 × 165 × 245	G ¼	640	160	-	0.7	6.1
500 × 140 × 150	9.0	RK 156 BH	646	530 × 165 × 300	G ¼	860	215	600	3.6	7.3
300 × 150 × 150	5.5	RK 255	3066	325 × 175 × 305	G ¼	640	160	-	0.7	5.2
		RK 255 H	316		G ¼	640	160	280	2.0	5.3
300 × 240 × 150	9.7	RK 510	327	325 × 265 × 305	G ½	640	160	-	0.7	7.0
		RK 510 H	321		G ½	640	160	400	2.5	7.6
300 × 240 × 200	13.0	RK 512 H	795	325 × 265 × 350	G ½	860	215	400	2.7	8.0
325 × 300 × 150	13.5	RK 514	277	355 × 325 × 305	G ½	860	215	-	1.0	8.2
		RK 514 H	207		G ½	860	215	600	3.6	8.8
325 × 300 × 200	18.7	RK 514 BH	263	355 × 325 × 385	G ½	860	215	600	3.6	9.8
500 × 300 × 200	28.0	RK 1028	322	535 × 325 × 400	G ½	1200	300	-	1.4	14.3
		RK 1028 H	324		G ½	1200	300	1300	7.0	14.7
500 × 300 × 300	45.0	RK 1028 C	661	540 × 340 × 500	G ½	2000	500	-	2.2	24.6
500 × 300 × 300	45.0	RK 1028 CH	143	540 × 340 × 500	G ½	1200*	300	1450	7.7	23.7
∅ 500 × 195	39.5	RK 1040	319	∅ 540 × 500	G ½	1200	300	-	1.4	20.5
600 × 500 × 200	58.0	RK 1050	323	655 × 535 × 425	G ½	2400	600	-	2.7	31.0
600 × 500 × 300	90.0	RK 1050 CH	184	640 × 540 × 530	G ½	2400*	600	1950	11.1	37.0

*4 times higher than HF output caused by modulation of ultrasound – SweepTec®

Programmable high-power ultrasonic baths with power setting, fast degassing and 10 program data memory



Applications:

- Degassing of solvents for HPLC
- Accelerating of chemical reactions
- Mixing of plasma and sera
- Emulsifying
- Homogenizing of samples for residue analysis in vegetarian food
- Preparation for pollutant analysis of drinking or drain water
- Preparation of liposomes in cosmetics and pharmacy
- Preparation of samples for analysis of THC-content in cannabis



Exact settings of all parameters guarantees reproducible results. Automatic storage of time, temperature and power when switching off.

Settings parameter

<p>Time Settings between 1 to 99 min and continuous operation. Interruption is possible at any time. Display of remaining time.</p>	<p>Temperature Heating adjustable between 20 to 80 °C (68 to 176° F). Display REAL: Bath temperature Display SELECT: Required temperature Integrated thermometer, accuracy ± 1 K</p>
<p>Power Settings from 10 to 100 %. Microprocessor controlled. Power constancy guarantees exact reproducibility.</p>	<p>DEGAS Rapid degassing of liquids. Higher degassing rates in HPLC-technique.</p>

Internal tank dimensions (l x w x d) mm	Capacity litres	Type	Code No.	External dimensions (l x w x h) mm	Drain ball valve	Ultrasonic peak output W	HF output W _{eff}	Heating power W	Current consumption A	Weight net kg
240 x 140 x 100	3.0	DK 102 P	780	260 x 160 x 250	-	480	120	140	1.2	4.5
500 x 140 x 150	9.0	DK 156 BP	781	530 x 165 x 300	G ¼	720	180	600	3.4	7.6
300 x 150 x 150	5.5	DK 255 P	782	325 x 175 x 295	G ¼	640	160	280	2.0	6.0
300 x 240 x 200	13.0	DK 512 P	783	325 x 265 x 350	G ½	820	205	400	2.7	8.8
325 x 300 x 200	18.7	DK 514 BP	784	355 x 325 x 385	G ½	860	215	600	3.6	10.2
500 x 300 x 200	28.0	DK 1028 P	786	535 x 325 x 400	G ½	1200	300	1300	7.0	15.2

*4 times higher than HF output caused by modulation of ultrasound – SweepTec®

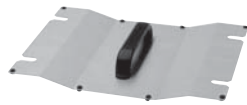

D 514

Lid D

stainless steel, to protect the liquid from outside dirt. Condensation water runs back into the tank.



K 14

Insert baskets K

stainless steel



PK 2 C

Insert baskets PK...C/K..P

plastic, with perforations, for gentle cleaning of sensitive surfaces.



GH 1

Utensil holders GH

stainless steel, mesh size 12.5 × 12.5 mm for larger objects. Utensil holder **GH 1**, suitable for flasks up to a diameter of 105 mm.



GH 10

Insert tubs KW

plastic, non-perforated and with lid. For working with chemicals that corrode the stainless steel oscillating tank. Insert tubs KW are made of PP, except for KW 3/5 made of PE. Stable up to a temperature of 80 °C (176° F) in water and up to 60 °C (140° F) in acids.



KW 3



KD 0



PD 04

Inset sieve baskets

mesh net, suitable for inset beakers.

KD 0

stainless steel, diameter 75 mm

PD 04

plastic, diameter 60 mm



SD 06



DD 06

Inset beakers

for indirect cleaning of small parts.

Suitable for **DE/ES**

SD 06, glass 600 ml

PD 06, plastic 600 ml

EB 05, stainless steel 600 ml diameter 85 mm, 100 mm deep, with retaining ring and lid DD 06.

SD 09, glass with ring 1000 ml



EB 05



PD 06

Suitable for DE 08

SD 04, glass, 400 ml

SD 05, glass, 600 ml

KB 04, plastic, 400 ml with ring



DE 100

Positioning lids DE

stainless steel, for inset beakers SD 06, PD 06, EB 05 and SD 09:

DE 52 for 1 beaker

DE 100/6/255 for 2 beakers

DE 156/510/514 for 4 beakers



ES 4

Beaker holder ES 4

stainless steel, for 4 inset beakers

SD 06, PD 06, EB 05, SD 09 - in ultrasonic baths of a larger size for optimum ultrasonic power.

Appropriate accessories facilitate ultrasonic application and simultaneously protect oscillating tank and parts to be cleaned. Objects to be cleaned or vessels must not be placed onto the tank bottom!

Type	RK 31 / H DT 31 / H	RK 52 / H DT 52 / H	RK 100 / H RK 102 H, DK 102 P DT 100 / H DT 102 H / H-RC	RK 103 H DT 103 H
Accessories				
Lids, s/s	D 08	D 52	D 100	D 100
Insert baskets, s/s l × w × h (mm)	K 08 170 × 65 × 50	K 1 C 120 × 110 × 40	K 3 C 200 × 110 × 40	K 3 CL 200 × 110 × 40
Insert baskets, plastic l × w × h (mm)	-	PK 1 C 90 × 90 × 66	PK 2 C 187 × 90 × 56	PK 3 C 187 × 90 × 56
Utensil holders l × w × d (mm)	-	GH 1 129 × 117	GH 1 129 × 117	GH 1 129 × 117
Insert tubs l × w × d (mm)	-	-	KW 3 195 × 115 × 88	KW 3 195 × 115 × 88
Positioning lids	DE 08	DE 52	DE 100	DE 100
Type	RK 510 / H DT 510 / H / H-RC	RK 512 H DT 512 H DK 512 P	RK 514 / H DT 514 / H	RK 514 BH DT 514 BH / BH-RC DK 514 BP
Lids, s/s	D 510	D 510	D 514	D 514
Insert baskets, s/s l × w × h (mm)	K 10 250 × 195 × 50	K 10 B 250 × 195 × 50	K 14 275 × 245 × 50	K 14 B 275 × 245 × 50
Utensil holders l × w × d (mm)	GH 10 260 × 200	-	-	-
Insert tubs l × w × d (mm)	KW 10-0 242 × 182 × 136	-	KW 14 280 × 215 × 145	KW 14 B 275 × 210 × 195
Positioning lids	DE 510	DE 510	DE 514	DE 514
Beaker holder				

Special accessories

Spring clamps for laboratory flasks

Neither floating nor canting of flasks. Fast and easy fixing to the bottom of insert baskets or utensil holders, with mesh sizes up to 12.5 x 12.5 mm.



K 10 with 2 EK 100

- EK 10** for 10-ml-laboratory flask to maximum dia. 31 mm, minimum dia. 23 mm
- EK 25** for 25-ml-laboratory flask to maximum dia. 42 mm, minimum dia. 30 mm
- EK 50** for 50-ml-laboratory flask to maximum dia. 52 mm, minimum dia. 35 mm
- EK 100** for 100-ml-laboratory flask to maximum dia. 65 mm, minimum dia. 40 mm
- EK 250** for 250-ml-laboratory flask to maximum dia. 85 mm, minimum dia. 55 mm

Suitable for baskets K 3 C/CL, K 5 C, K 6, K 10/B, K 14/B, K 28/C, utensil holders GE 10 and GH 28, flask holder 510 F and shaking device SA 1028

Handle adjustment for insert baskets and utensil holders – registered pattern DE 200 071 14

Stepless adjustment of immersion depth, no floating, tipping over or flooding of laboratory flasks. Quick and easy to attach.

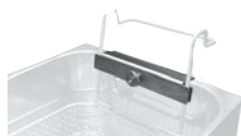

GV 10

GV 3 - 2 pieces suitable for baskets K 1 C, K 3 C/CL K 5 C, K 6 BL

GV 10 - 2 pieces suitable for baskets K 10/B, K 14/B, K 28/C and utensil holders GH 10 and GH 28

Test tube holder

RG 2, stainless steel

For sonication of 6 test tubes up to a diameter of 25 mm and 8 test tubes up to a diameter of 16 mm. Also applicable as a test tube rack. Contents of the test tubes remain visible.

Suitable for ultrasonic units DT 52/H, DT 100/H, DT 102 H/H-RC, RK 52/H, RK 100/H, RK 102 H, RK 103 H, DK 102 P



RG 2

Tabletting punch holder

For tabletting punches with different diameters:

TH 14 B für RK/DT 514 BH
holes with dia. 22 mm for 30 punches EU B
holes with dia. 28 mm for 30 punches EU D

TH 14 B-S 22 for RK/DT 514 BH
holes with dia. 22 mm for 60 punches EU B

TH 14 B-S 28 for RK/DT 514 BH
holes with dia. 28 mm for 52 punches EU D

TH 28-S 22 for RK/DT 1028 H
holes with dia. 22 mm for 44 punches EU B

TH 28-S 28 for RK/DT 1028 H
holes with dia. 28 mm for 31 punches EU D

TH 28 C-S 22 for RK/DT 1028 CH
holes with dia. 22 mm for 44 punches EU B

TH 28 C-S 28 for RK/DT 1028 CH
holes with dia. 28 mm for 31 punches EU D

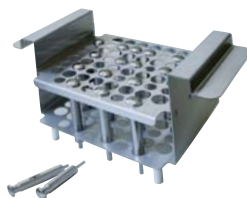

TH 14 B-S 22

Type	RK 106 DT 106	RK 156 DT 156	RK 156 BH DK 156 BP DT 156 BH	RK 255 / H DT 255 / H / H-RC DK 255 P
Accessories				
Lids, s/s	D 6	D 156	D 156	D 255
Insert baskets, s/s l x w x h (mm)	K 6 Ø 215 x 50	K 6 L 460 x 100 x 50	K 6 BL 460 x 100 x 50	K 5 C 260 x 110 x 40
Insert baskets, plastic l x w x h (mm)	-	-	-	K 5 P 254 x 96 x 130
Utensil holders l x w x d (mm)	-	-	-	-
Insert tubs l x w x d (mm)	-	-	-	KW 5 254 x 96 x 130
Positioning lids	DE 6	DE 156	DE 156	DE 255

Type	RK 1028 / H DT 1028 / H DK 1028 P	RK 1028 C RK 1028 CH DT 1028 CH	RK 1040	RK 1050	RK 1050 CH DT 1050 CH
Accessories					
Lids, s/s	D 1028	D 1028 C	D 40	D 1050 C	D 1050 C
Insert baskets, s/s l x w x h (mm)	K 28 455 x 245 x 50	K 28 C 455 x 245 x 50	K 40 Ø 480 x 50	K 50 545 x 450 x 50	K 50 C 545 x 450 x 50
Utensil holders l x w x d (mm)	GH 28 455 x 250	-	-	-	-
Insert tubs l x w x d (mm)	KW 28-0 437 x 230 x 155	KW 28-0 437 x 230 x 155	-	KW 50-0 517 x 445 x 184	KW 50 B-0 520 x 445 x 284
Positioning lids	-	-	-	-	-
Beaker holder	ES 4	ES 4	-	ES 4	ES 4

Specific applications



RK 1028 C with SH 28 C



DT 106 with SH 7

Careful cleaning of analysis sieves

Analysis sieves are test equipment and require careful cleaning. Clean sieves are necessary for safe results.

Sieve holder SH 7

Code No. 314

stainless steel, for single cleaning of analysis sieves up to dia. 200 mm, max. height 50 mm, suitable for ultrasonic baths RK 106, DT 106

Sieve holder SH 28 C

Code No. 307

stainless steel, allows simultaneous cleaning of up to 5 analysis sieves dia. 200 mm, suitable for ultrasonic bath SONOREX SUPER RK 1028 C

Ultrasonic bath for single-cleaning of analysis sieves up to dia. 400 mm:
SONOREX SUPER RK 1040

Recommended cleaning concentrate: TICKOPUR R 33

Pipette cleaning

Short cleaning time. No time-consuming washing. Rinsing process in the same vessel using the siphon principle - no shifting around. Accelerated circulation of pipettes. No glass breakage when used according to the operating instructions. Also suitable for burettes, other glassware and plastic pipettes.

Max. length of objects to be cleaned: 765 mm.

Technical data:

Operating capacity 13.9 l, operating depth 765 mm, height of the device 1,130 mm, **please note that 800 mm free space above the cylindrical vessel is necessary for loading**, required floor space 335 x 255 mm, ultrasonic peak output 860 W, HF output 215 W_{eff} 35 kHz, SweepTec®, radiating surface diameter 150 mm, timer 1 to 15 min or continuous, mains connection 230 V~, 50/60 Hz, on request 115 V~.

Quantity of pipettes to be cleaned - suitable for K 140 B:

- diameter 9.0 mm – ca. 90 pieces
- diameter 10.7 mm – ca. 55 pieces
- diameter 14.0 mm – ca. 35 pieces
- diameter 20.0 mm – ca. 15 pieces
- diameter 2.0 mm – ca. 10 pieces

SONOREX PR 140 C

Ready-to-use set consisting of:

- pipette cleaner PR 140 C
- pipette basket K 140 B
- lid D 140
- cleaning concentrate: TICKOPUR R 33 – 5 litres

Code No. 3257

Three-way valve to change from tap water to DI-water (for final rinsing)

AR 140 C, metal

Code No. 017

AR 140 CP-1, plastic

Code No. 3039

Pipette basket K 140 B, plastic

Code No. 703

Lid D 140, made of stainless steel

Code No. 676

Cleaning and disinfecting of breathing masks in a single operation

thorough - reliable removal of dirt from internals or even from angles and corners

gentle - no scratching by manual treatment

economical - cleaning and disinfecting of up to 15 breathing masks in one process

Ultrasonic bath SONOREX SUPER RK 514 BH

with insert basket K 14 AZ for 2 breathing masks or 1 full mask

Ultrasonic bath SONOREX SUPER RK 1028 CH

with insert basket K 28 CA for 6 breathing masks

with insert basket K 28 CV for 3 full masks

Ultrasonic bath SONOREX SUPER RK 1050 CH

with insert basket K 50 CA for 9 breathing masks

with insert basket K 50 CV for 6 full masks

Ultrasonic bath SONOREX TECHNIK RM 180 UH

with insert basket MK 180 A for 15 breathing masks

Detailed documentation on request.



dirty

cleaned by ultrasound



SONOREX SUPER RK 1028 CH
with basket K 28 CA for 6 breathing masks

EXAM-expertise concerning material compatibility:

Cleaning and disinfecting concentrate **STAMMOPUR 24**

Universal cleaning concentrate **TICKOPUR R 33**

Why do you need special agents for ultrasonic cleaning?

Ultrasound and water without any additives do not clean!

Besides ultrasonic power, temperature and relevant processing time, specially balanced cleaning agents are also necessary to achieve optimum cleaning results. With TICKOPUR cleaning concentrates, BANDELIN offers a wide range of adequate cleaning agents.

All of the TICKOPUR cleaning agents were specially developed for ultrasonic applications. With their cavitation-aiding properties, the cleaning concentrates support the cleaning process and are gentle to the material at the same time. Depending on the cleaning tasks, either alkaline, neutral or acidic cleaning agents are recommended. They are biologically degradable and easy to dispose of. Rinsing after cleaning is necessary to remove remaining residues of cleaning agents and diluted soil particles from the parts to be cleaned.

It is not allowed to use combustible liquids directly in the ultrasonic bath.

Household cleaners, acids and most of the customary acid cleaners are improper cleaning agents because they could destroy the tank by pitting corrosion resulting finally in breakdown of the ultrasonic bath.



Optimum cleaning results with ultrasound require appropriate cleaning agents.

Contamination	Objects to be cleaned	Cleaning agents	Litres
General contamination, oily and greasy residues, soot, ink, drilling, grinding, polishing and lapping residues etc.	Glass, ceramics, plastics, rubber, steel, stainless steel, non-ferrous-, precious- and light metals, sieves, pipettes, respirators, PC-boards, glasses. Caution with tin and zinc.	TICKOPUR R 33 – EXAM-expertise universal cleaner with anticorrosive, for laboratory, service and industry, gentle cleaning, mildly alkaline, pH 9.9 (1 %), dosage 1 to 5 %, 1 to 10 min	2 5 25 200
Light drilling, grinding, polishing and lapping residues, dust, soot, oily and greasy residues etc.	Glass, ceramics, plastics, rubber, steel, stainless steel, non-ferrous-, precious- and light metals.	TICKOPUR R 30 neutral cleaner - gentle cleaning, anticorrosive, neutral, pH 7 dosage 1 to 5 %, 1 to 10 min	2 5 25 200
Heavy mineral residues like limescale, silicate, phosphate, rust, cement, temper colours, metal oxides, grease and oil films etc.	Glass, ceramics, plastics, rubber, steel, stainless steel, precious metals. Not for light and non-ferrous metals, tin and zinc!	TICKOPUR R 27 special cleaner - based on phosphoric acid, anticorrosive, acid, pH 1.9 (1 %), dosage 5 %, 1 to 10 min	2 5 25 200
Resinous residues, soot, grease, oils, waxes, pigments, coloured fog, silicon oils, flux media, oxides at copper, brass, bronze and precious metals.	Glass, ceramics, plastics, rubber, steel, stainless steel, non-ferrous- and precious metals, analysis sieves. Caution with light metals.	TICKOPUR RW 77 special cleaner with ammonia, without phosphate, gentle to material, mildly alkaline, pH 9.9 (1 %), dosage 5 %, 1 to 10 min	2 5 25 200
Coke residues, resinous residues, soot, pigments, grease, oils, waxes, silicon oils, coloured fog, drilling, grinding, polishing and lapping residues etc.	Glass, ceramics, plastics, rubber, steel, stainless steel. Not for light metals, tin and zinc!	TICKOPUR R 60 intensive cleaner , without phosphate, strongly alkaline, pH 12.8 (1 %) dosage 2 to 20 %, 1 to 10 min	2 5 25 200
Steel, stainless steel, non-ferrous, precious and light metals, glass, ceramics, plastics, rubber.	Mineral residues, drifting rust, grease, oils, waxes, pigments, drilling, grinding, polishing and lapping residues.	TICKOPUR TR 3 special cleaner based on citric acid, gentle cleaning, without phosphate, anticorrosive, weakly acid, pH 3.0 (1 %), dosage 5 %, 1 to 10 min	2 5 25 200
Steel, stainless steel, glass, ceramics, plastics, rubber Not for tin, zinc and light metals! Non-ferrous metals can be affected.	Coke residues, resinous residues, soot, grease, oils, waxes, pigments, coloured fog, drilling, grinding, polishing and lapping residues.	TICKOPUR TR 13 intensive cleaner , demulsifying, for stubborn contamination, without phosphate and silicate, alkaline, pH 11.9 (1 %) dosage 0.1 to 10 %, 1 to 10 min	2 5 25 200
General contamination, biofilms, soot, pigments, oil- and fat-containing residues etc.	Instruments, pipettes, respirators, protective goggles, laboratory equipment, etc.	STAMMOPUR 24 VAH certified, EXAM-expertise intensive instrument cleaning and disinfection Residue-free rinsing, neutral scent. Very gentle to material. Free from aldehydes, chlorine and phenols. Active against bacteria (incl. Tb.-B.), fungi, virucidal against Vaccinia, BVDV, H5N1, HBV, HCV, HIV, mildly alkaline, pH 9.4 (1 %), Application in the ultrasonic bath 1 % – 15 min, 2 % – 5 min	2 5 25

SONOREX DIGITEC DT... F flat ultrasonic baths with fast degassing function for sample preparation

Uniform sonication of samples irrespective of size and arrangement of the flasks. Homogenizing or fast degassing of samples at the push of the button – sample preparation in laboratory flasks.

Internal tank dimensions (l x w x d) mm	Capacity litres	Type	Code No.	External dimensions (l x w x h) mm	Drain ball valve	Ultrasonic peak output * W	HF output W _{eff}	Current consumption A	Weight net kg
300 x 240 x 65	4.3	DT 510 F	3242	325 x 265 x 195	G ½	560	140	0.7	5.2
500 x 300 x 65	9.5	DT 1028 F	3243	535 x 325 x 205	G ½	1280	320	1.4	9.7

*4 times higher than HF output caused by modulation of ultrasound – SweepTec®





Basic set:

- Ultrasonic bath SONOREX DIGITEC DT 510 F, flask holder GL 510 F, 250 ml TICKOPUR TR 3
- Ultrasonic bath SONOREX DIGITEC DT 1028 F, 2 flask holders GL 510 F, 250 ml TICKOPUR TR 3



SONOREX DIGITEC DT 1028 F
with 2 flask holders GL 510 F

TICKOPUR TR 3, concentrate for producing the contact liquid.
Spring clamps EK are necessary to fix the laboratory flasks fast and easy to the flask holder GL. Floating or canting of flasks is prevented.

Flask size Type	10 ml EK 10 	25 ml EK 25 	50 ml EK 50 	100 ml EK 100 	250 ml EK 250 
Code No.	051	053	055	057	3259
for GL 510 F are suitable	18 x	18 x	9 x	6 x	5 x

See also page 9 info to flasks size.

SONOSHAKE® – Ultrasonic bath SONOREX DIGITEC DT 1028 F combined with shaking device SA 1028 – registered pattern DE 20 2009 017 749.1

SONOSHAKE offers a wide range of possible applications for sample preparation in many areas of analysis, for example, in environmental and foodstuffs analytics as well as in the area of medical diagnostics. The bath has a basic area of 500 mm x 300 mm and a tank depth of only 65 mm, making it ideal for sonication of samples in laboratory flasks. The samples can be sonicated either for a selected period or in continuous mode. Quick degassing using the DEGAS function is also possible. With four different shaking frequencies, the shaking device enables gentle to vigorous reciprocating motion up to a maximum of 20 mm. Both procedures can be carried out simultaneously or separately. This means that, for example, a sample can be pre-homogenized at a specified shaking frequency, and then final homogenization can be achieved in a very short time using ultrasound.



SONOSHAKE®

Consisting of:

- Ultrasonic bath DT 1028 F
- shaking device SA 1028

Code No. 3257

Shaking device SA 1028

- analogue setting of time (1 – 15 min or continuous) and shaking frequency
- reciprocating motion: settings in 4 steps possible of up to 200 rpm
- constant amplitude of 20 mm independently of loading
- rack easy to remove
- easy mounting of the laboratory clamps EK 10 –250 (ordering separately)
- shaking platform approx. 410 x 280 mm (l x w)
- mounting of 36 x 10-ml-flasks or 36 x 25-ml-flasks or 18 x 50-ml-flasks or 12 x 100-ml-flasks or 10 x 250-ml-Kolben
- required floor space of SONOSHAKE approx. 850 x 360 mm (l x w)

The shaking device SA 1028 can also be added to existing SONOREX DIGITEC DT 1028 F ultrasonic baths.

Code No. 3249



SA 1028

Ultrasonic special device for gentle removing of biofilm

Fast microbiological diagnostic method for implant-associated infections

The successful treatment of implant infections depends on an accurate microbiological diagnosis. Microorganisms form biofilms on implant surfaces, what makes them difficult to detect by conventional methods. BactoSonic® gently removes biofilms from implant surfaces.

Principle of BactoSonic®

The implants are placed in the air-tight implant boxes and sonicated in the specially designed ultrasonic device BactoSonic®. Compared to other ultrasonic baths, BactoSonic® works with a very low ultrasound intensity. The biofilm is removed without killing the bacteria, a quantitative assessment is possible.

The sonicated liquid is cultured and the quantity of bacteria can be determined. Compared to standard methods (e. g. biopsies from periprosthetic tissue) up to 10,000 times more bacteria can be detected. Mixed infections and different bacteria morphotypes can better be identified. The sensitivity especially of patients with previous antibiotic therapy is improved.



BactoSonic 14.2

Ready-to-use set consisting of:

- Ultrasonic special device BS 14
- scientifically tested procedure
- wire frame for foil test FT 14
- TICKOPUR TR 3 (contact liquid, concentrate) – 250 ml

Implant boxes	Dimensions mm (l × w × h)	Box trays for implant boxes
IB 5, PP, 0.52 l - 2 pcs	145 × 110 × 67	BT 5, PC, for 2 pcs IB 5
IB 6, PP, 0.6 l - 2 pcs	dia. 142 × 68	BT 6, PC, for 2 pcs IB 6
IB 10, PP, 1.0 l - 1 pcs	278 × 115 × 60	BT 10, PC, for 1 pcs IB 10
IB 18, PP, 1.8 l - 1 pcs	208 × 143 × 94	BT 18, PC, for 1 pcs IB 18
IB 20, PP, 2.0 l - 1 pcs	135 × 102 × 282	GH 14, stainless steel, for 3 pcs IB 20

PP = Polypropylen (plasma sterilisable), PC = Polycarbonat (plasma sterilisable)

Code No. 3290

Implant boxes vor ordering seperately:

Typ	Pkg Qty (pieces)	Code No.
IB 5	5	3280
IB 6	5	3281
IB 10	5	3282
IB 18	5	3283
IB 20	5	3284



Technical data

Inner tank dimensions, stainless steel:	325 × 300 × 150 mm (l × w × d)	HF output:	max. 200 W _{eff} **
Filling volume for operation:	9.5 litres (contact liquid)	Frequency:	40 kHz
Exterior dimensions:	355 × 325 × 305 mm (l × w × h)	Current consumption:	1.0 A
Drain:	ball valve G ½, left side	Mains connection:	230 V~, 50/60 Hz
Timer:	1 – 15 min and ∞		115 V~, 50/60 Hz
Power selection switch:	adjustable 20, 40, 60 80 and 100 %	Weight with accessories:	14.0 kg

**Exceptionally homogeneous sound field with low intensity for a constant and gentle sonification.

Ultrasonic device with cooling for use in pathology and analysis laboratories



SC 255

Decalcification of bone tissue in pathology

Decalcifying of bone tissue is an important step of histological preparation of samples (e.g. in oncology). Only decalcified samples can be used artefact-free for followed diagnosis. Compared to standard methods, the processing time is extremely shortened.

- no destroying of the morphologic structure of samples
- quantity of aggressive decalcifying liquids is reduced
- faster results of diagnosis

Use in analysis laboratories

With SONOCOOL® the catalytic effect of ultrasound can also be used when sonicating temperature-sensitive samples. Exotherm reactions are possible because of the integrated cooling system, processes are faster and more effective.

SONOCOOL 255

Ready-to-use set consisting of:

- ultrasonic device SC 255
- sample holder PH 255-11 for 11 inset beakers SD 01.2
- lid made of glass D 255 G
- 20 inset beakers SD 01.2, glass – without spout, 20 pieces à 100 ml,
- 250 ml TICKOPUR TR 3 (concentrate for producing the contact liquid)

Code No. 3500



sample holder PH 255-11 with inset beakers SD 01.2





Advantages:

- compact design
- increased life span by welded tank: stainless steel AISI 316Ti, 2 mm thick
- lid made of glass for sample observation and easy cleaning
- level sensor for contact liquid as dry run protection
- lighted LCD display for remaining time – actual temperature – pause/diagnostics – set time/set temperature – ultrasonic power
- serial interface for remote control

Technical data

Inner tank dimensions:	280 × 150 × 150 mm (l × w × d)
Tank volume:	5 litres (contact liquid)
Adjustable bath temperature:	15 – 40 °C (at 20 °C room temperature)
Cooling power:	200 W
Ultrasonic power:	180 W, adjustable in 4 steps
Ultrasonic frequency:	35 kHz, SweepTec®
Countdown operation:	up to 100 h
External dimensions:	360 × 605 × 385 mm (l × w × h)
Housing:	aluminium: coated with flush pulls (grips recessed inside the housing)
Outlet:	front left, concealed
Current consumption:	1.6 A
Mains connection:	230 V~, 50/60 Hz
Weight:	27.5 kg

Accessories

<p>Sample holder PH 255-11 for 11 inset beakers SD 01.2 Code No. 3512</p>	 <p>The image shows a white metal sample holder with 11 circular wells. To its left is a single glass inset beaker with a scale. To its right is the same sample holder with 11 glass inset beakers inserted into the wells.</p>
<p>Inset beaker SD 01.2 Pkg Qty = 10 pieces, à 100 ml, made of glass, without spout, inner dia. 44 mm, 80 mm high Code No. 3517</p>	
<p>Sample holder PH 255-1 for 1 box IB 18 Code No. 3519</p>	 <p>The image shows a white metal sample holder with a single large rectangular well. To its left is a clear plastic box with a blue lid. To its right is the sample holder with the plastic box inserted into the well.</p>
<p>Box IB 18 Pkg Qty = 5 pieces Code No. 3283</p>	
<p>Sample holder PH 255-2 for 2 inset beakers SD 06 Code No. 3518</p>	 <p>The image shows a white metal sample holder with two circular wells. To its left is a glass inset beaker with a lid. To its right is the sample holder with two glass inset beakers inserted into the wells.</p>
<p>Inset beaker SD 06, made of glass, 600 ml, inner dia. 84 mm, 125 mm high, with lid, inset is made without black ring Code No. 330</p>	
<p>Lid D 255 G made of glass Code No. 3515</p>	 <p>The image shows a rectangular glass lid with a small black knob in the center.</p>
<p>Hose holder SCH 255 for connecting a pump Code No. 3520</p>	 <p>The image shows a white plastic hose holder. To its right is a small electronic device, likely a pump, with a hose connected to it.</p>

Applications

- Decalcification of bone samples from surgical preparations of malignant osteogenous tumors
- Decalcification of dental hard tissue for a histopathological specimen
- Demineralization of bony tissue samples by very good preservation of tissue structures (spongiosa, cortical bone, marrow cavity tissue, cartilage, connection tissue)

SONOPULS Features

AMPLICHRON®-system

guarantees a constant amplitude independently from changing conditions within the sample. It for reproducible results. Settings within a range of 10 to 100 % are possible. Verification of actual value at the display. Permanent control of ultrasound irradiation as well as indication of wear of the probe.

Pulsation

limits temperature increase when processing heat-sensitive samples. The adjustable pulsation allows cooling during rest intervals.

Continuous operation

Constant sound radiation – extremely effective.

Built-in timer

Process duration storable. Indication of elapsed time in continuous operation or of remaining time in countdown mode.

Switching ON / OFF - easy to handle

either at the generator or directly at the ultrasonic converter via button or remote control.

Accessories

A wide range of probes and special accessories for a vast variety of applications.

Foil keypad

easy to clean and user-friendly.

ROHS compliant

Devices are built lead free.

Fail-safe during continuous operation and idling

CE-marked, also as medical device compliant to the directive for in-vitro diagnostics 98/79/EG

Features	mini20	HD 2000 series	HD 3000 series
Sample volume	0,1 – 25 ml	1 – 1000 ml	1 – 2500 ml
Amplitude control	10 – 100 %	10 – 100 %	10 – 100 %
Power control	yes (HF power)	no	yes (HF power)
Automatic amplitude limiting	yes	no	yes, after preselection of probe
Pulsation	ON cycles 0,1–60 s OFF cycles 0,2–60 s	10–100 % – storable (duty cycle, base 1 sec)	ON cycles 0,2–600 s OFF cycles 0,3–600 s
Time modes	50 min: 59 s	99 min: 59 s continuous or timed	9 h: 59 min: 59 s continuous or timed
Safety shut down	50 min: 59 s	no	9 h: 59 min: 59 s
Display	grafic / alphanumeric liquid crystal display of amplitude, pulsation mode, time, energy	numerical seven-segment display of amplitude, pulsation mode and time	grafic / alphanumeric liquid crystal display of amplitude, pulsation mode, time, energy and optionally temperature
Menu guided	comfortable setting of all values through „push & turn“	no	comfortable setting of all values through „push & turn“
Energy monitoring	in kJ	no	in kJ
Temperature monitoring and measurement	no	no	optional, 0–120 °C, temperature probe necessary, optional signal tone or switch - off
User programs	9	1	9, with software WINPULS®: 99
Remote control with PC	RS 232 (infrared)	no	RS 232 (infrared)
PC-Software, optionally available	no	no	WINPULS®
Error diagnosis	yes	no	yes
Processing frequency	30 kHz	20 kHz	20 kHz
Automatic storage of the last adjusted values	yes	no	yes
Operating test	yes	no	yes
Remote control	no	foot switch	foot switch

How to select the proper unit

Power output in watt is not the sole criterion for selecting an ultrasonic homogenizer. This value only indicates the power of the HF-generator but not the energy delivered to the sample. The amplitude at the radiating surface of the probe is the determining factor for the evaluation of the irradiation result while taking into consideration the volume of the sample.

SONOPULS Functioning

HF generator:

Transforming of low-frequency voltage of 50 Hz into high-frequency voltage of 20 kHz.

Ultrasonic converter:

Transforming of electrical voltage delivered from the generator into mechanical vibrations of 20 kHz.

Standard and booster horns:

Increasing of amplitude by their specially designed shape. The external thread is made for close connection of vessels.

Probes:

Transmitting of ultrasonic energy into the sample. Microtips, tapered and flat tips, dia. 2, 3, 6, 13, 19 and 25 mm, for use in different volumes.

Material: Ti-Al6-V4



Operating panel HD 2070 / HD 2200

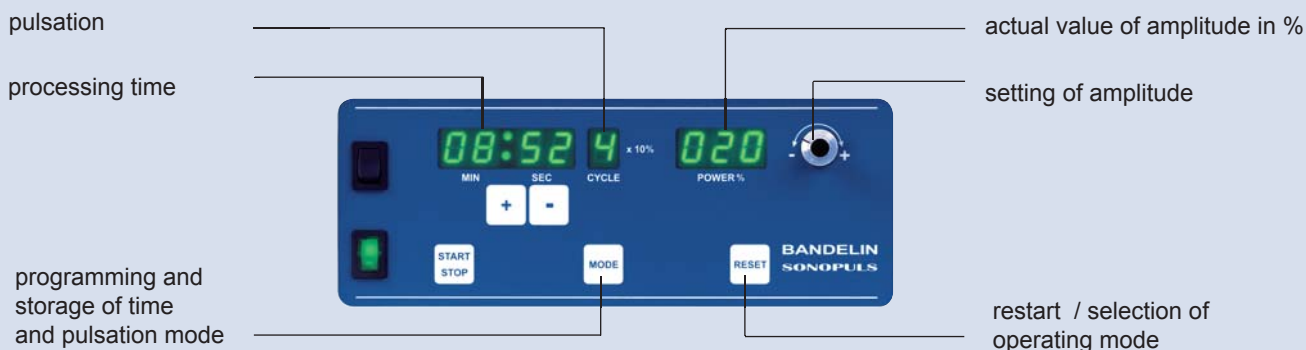

Operating panel HD 3100 / HD 3200 / HD 3400

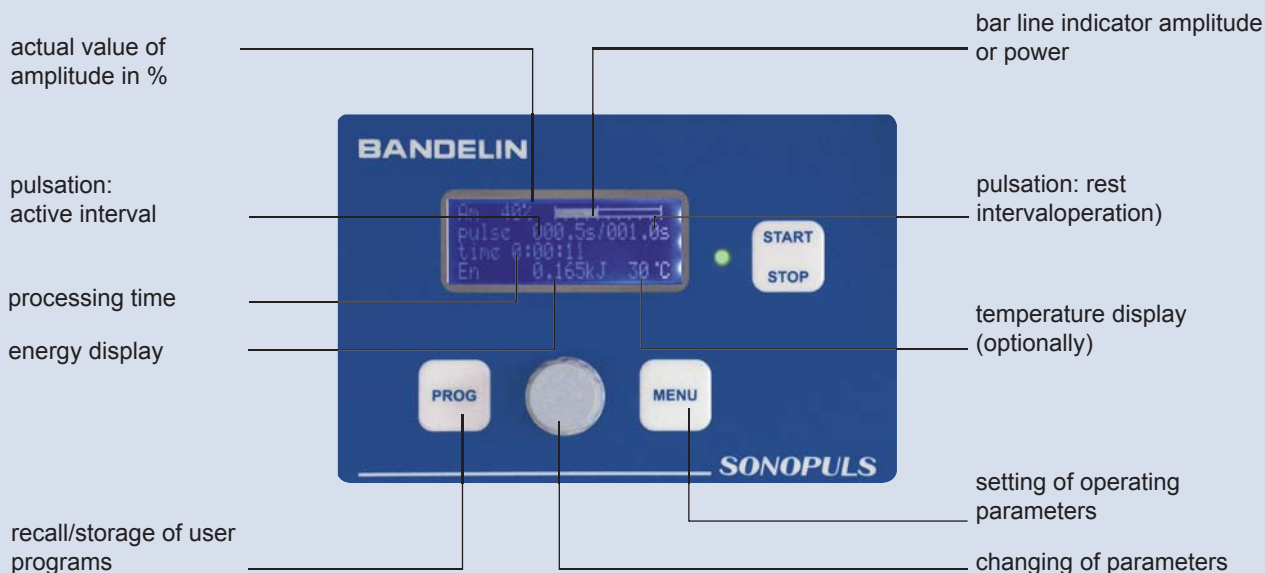

SONOPULS Ultrasonic homogenizers

Fast hand operation

SONOPULS mini20 for volumes up to 25 ml

Ready-to-operate for volumes from 0.5 ml to 25 ml, consisting of:

- HF generator mini20
- ultrasonic converter mini20
- microtip MS 2.5, diameter 2.5 mm

HF output max. 20 W_{eff}

Code No. 3665



Pulsation on pressing the bottom at the ultrasonic converter by thumb.

Small unit for lab routine

SONOPULS HD 2070 for volumes up to 200 ml

Ready-to-operate basic equipment for volumes from 2 ml to 50 ml consisting of:

- HF generator GM 2070
- ultrasonic converter UW 2070
- standard horn SH 70 G
- microtip MS 73, diameter 3 mm

HF output max. 70 W_{eff}

Code No. 2450



Standard unit for lab routine

SONOPULS HD 2200 for volumes up to 1000 ml

Ready-to-operate basic equipment for volumes from 20 ml to 900 ml consisting of:

- HF generator GM 2020
- ultrasonic converter UW 2200
- booster horn SH 213 G
- titanium flat tip TT 13, diameter 13 mm

HF output max. 200 W_{eff}

Code No. 2530



HF generator		GM mini20	GM 2070	GM 2200
dimensions, l × w × h	mm	250 × 256 × 154	257 × 180 × 115	257 × 180 × 115
weight	kg	2.0	2.5	2.5
mains supply		230 V~, 50/60 Hz, optionally 115 V~, 50/60 Hz	230 V~, 50/60 Hz, optionally with voltage selector for 115 V~, 50/60 Hz	
converter		UW mini20	UW 2070	UW 2200
dimensions, diameter × l	mm	50 × 160	70 × 120	70 × 120
weight	kg	0.27	1.0	1.0
available titanium probes, diameter	mm	1.5, 2.0, 2.5	2, 3, 6, 13	2, 3, 6, 13, 19, 25

SONOPULS Ultrasonic homogenizers

High-Tech for research

SONOPULS HD 3100

for volumes up to 200 ml

Ready-to-operate for volumes from 2 ml to 50 ml, consisting of:

- HF generator GM 3100
- ultrasonic converter UW 3100
- standard horn SH 70 G
- microtip MS 73, diameter 3 mm

HF output max. 100 W_{eff}

Code No. 3680



High-Tech for research

SONOPULS HD 3200

for volumes up to 1000 ml

Ready-to-operate for volumes from 20 ml to 900 ml, consisting of:

- HF generator GM 3200
- ultrasonic converter UW 3200
- booster horn SH 213 G
- titanium flat tip TT 13, diameter 13 mm

HF output max. 200 W_{eff}

Code No. 3660



High-Tech for research and pilot plant stations

SONOPULS HD 3400

for volumes up to 2500 ml

Ready-to-operate for volumes from 100 ml to 2500 ml, consisting of:

- HF generator GM 3400
- ultrasonic converter UW 3400
- booster horn SH 3425
- extended probe VS 200 T, diameter 25 mm

HF output max. 400 W_{eff}

Code No. 3690



HF generator		GM 3100	GM 3200	GM 3400
dimensions, l × w × h	mm	250 × 256 × 154	250 × 256 × 170	324 × 230 × 131
weight	kg	2.0	2.7	3.1
mains supply		230 V~, 50/60 Hz, optionally 115 V~, 50/60 Hz		230 V~, 50/60 Hz
converter		UW 3100	UW 3200	UW 3400
dimensions, diameter × l	mm	70 × 120	70 × 120	90 × 180
weight	kg	1.0	1.0	2.2
available titanium probes, diameter	mm	2, 3, 6, 13	2, 3, 6, 13, 19, 25	19, 25

SONOPULS Applications

Ultrasonic homogenizers are used in laboratories, hospitals and in industry for scientific experiments and analysis as well as in pilot or small lot production. Here are some examples showing the vast variety of applications for ultrasonic homogenizers:

Typical areas of application

- Disruption of cells, bacteria, virus, tissue, also mixed tissue
e. g. for extraction of cell contents
- Emulsifying of hardly mixable liquids, e.g. oil and water, particle size in μm range
- Deagglomeration of nanoparticles in material research (nanostructured material) in medicine, biotechnology, automobile industry
- Acceleration of chemical reactions
- Production of dispersions

Analysis

- Preparing samples for grain size determination or environmental analysis:
HD 3200 or **HD 2200** with tapered tip **KE 76** or with extended probe **VS 70 T**.
- Homogenizing of cheese samples for determination of nitrates:
HD 3200 or **HD 2200** with **MS 73**

Biochemistry - Biology - Medicine

- Sonication of small high-quality samples for analysis like EIA or RIA:
HD 3100 and **HD 2070** with microtip **MS 72** or **MS 73**.
- Due to high amplitudes, disruption of high-resistant bacteria, cells or tissues is possible. Indirect processing of sample in cup booster **BR 30** or in cup horns **BB 2 G** or **BB 6** is recommended to avoid cross-contamination.
- Detection of prions by cyclic amplification of protein misfolding:
HD 2070 with **MS 73**
- Simultaneous sonication of 12 samples in microplates:
HD 3100 with **MR 12-2**

Chemistry and Sonochemistry

- Acceleration of chemical reactions or destroying of highly-molecular compounds:
HD 3200 or **HD 2200** with tapered tip **KE 76** and sleeve adapters **NA 29 G** or **NA 45 G** for tight fitting to a sonochemical reaction vessel.

Pharmacy - Cosmetic

- Production of larger volumes of long lasting emulsions, e. g. lotions and production of antigens, vaccines or liposomes:
HD 3200 or **HD 2200** with flow-through cell **DG 4 G**



Waste water samples

Aim: Homogenizing for determination of harmful substances, e.g. mineral oil, grease AOX in industrial and butcher's waste water

Quantity: 250 ml

Approx.time: 5 - 10 min

Unit: HD 2200/3200 with TT 13,
or taller vessels with VS 70 T

Aluminium oxide suspensions

Aim: Dispersing

Quantity: 100 ml

Approx.time: ca. 4 min

Unit: HD 3200 with KE 76

Soil samples

Aim: Extraction for determination of pH value, Mg, K, P, N – contents for recommendation of fertilizer / determination of radio nucleides to control radioactivity in the environment (milk research)

Quantity: 50 - 100 ml / 100 - 150 ml

Approx.time: a few seconds

Unit: HD 2200/3200 with KE 76 / VS 70 T

Bladder tissue

Aim: Disruption

Quantity: 1,5 ml

Approx.time: ca. 1,5 min

Unit: HD 2200 with MS 72, cooling necessary

Candida albicans

Aim: Disruption

Quantity: 10 ml

Approx.time: ca. 10 min

Unit: HD 2070/3100 with MS 73

ChIP (Chromatin immunoprecipitation)

Aim: DNA fragmentation

Quantity: 1 ml

Approx.time: ca. 2 min

Unit: HD 3200 with MS 72

Large intestine tissue

Aim: Disruption

Quantity: 1,5 ml

Approx.time: ca. 3 min

Unit: HD 2200 with MS 72, cooling necessary

Dispersing of solid particles

Aim: granulometric measurement

Quantity: 50 - 100 ml

Approx.time: ca. 2 - 5 min

Unit: HD 2200/3200 with KE 76

Small intestine tissue

Aim: Disruption

Quantity: 1,5 ml

Approx.time: ca. 2,5 min

Unit: HD 2200 with MS 72, cooling necessary

Escherichia coli

Aim: Disruption for proteine lay off

Quantity: 10 ml

Approx.time: ca. 5 - 10 min

Unit: HD 2070/3100 with MS 73 or HD 2200 with MS 73

Eucaryotic cells

Aim: Disruption for proteine lay off

Quantity: 1,5 ml

Approx.time: ca. 1 min

Unit: HD 2200/3200 with BR 30 u. EH 3, cooling necessary

Meat and sausage samples

Aim: Homogenizing for determination of nitrates

Quantity: 100 ml

Approx.time: ca. 3 min

Unit: HD 2200/3200 with KE 76

Heart muscle tissue

Aim: Homogenizing

Quantity: 1,5 ml

Approx.time: ca. 4 min

Unit: HD 2200/3200 with MS 72, cooling necessary

Brain tissue

Aim: Disruption

Quantity: 1,5 ml

Approx.time: ca. 1 min

Unit: HD 2200 with MS 72, cooling necessary

Yeast cells

Aim: Disruption

Quantity: 10 ml

Approx.time: ca. 2 min

Unit: HD 3200 with MS 73

Insect cells

Aim: Disruption for proteine lay off

Quantity: 20 - 50 ml

Approx.time: ca. 25 sec, pulsed

Unit: HD 2070/3100 with MS 73 and RZ 2

Liver tissue

Aim: Homogenizing for molecular genetic tests

Quantity: 1,5 ml

Approx.time: ca. 1½ min

Unit: HD 2200/3200 with MS 72, cooling necessary

Liposomes

Aim: Producing of small unilamellar phospholipid vesicles

Quantity: 20 ml

Approx.time: ca. 10 - 15 min

Unit: HD 2070/3100 with TT 13,
cooling necessary

Lymphocytes

Aim: Disruption

Quantity: 50 µl - 2 ml

Approx.time: ca. 1 - 5 min

Unit: HD 2070/3100 with BR 30 and EH 3

Nano emulsions

Aim: Drop sizes within nm range

Quantity: 2 ml

Approx.time: ca. 5 min

Unit: HD 3100 with MS 72,
cooling necessary

Nano particles

Aim: Dispersing

Quantity: 100 ml

Approx.time: ca. 2 min

Unit: HD 3200 with KE 76

Retina

Aim: Tissue disruption

Quantity: 60 ml

Approx.time: 15 short strokes

Unit: mini20 with MS 2.5

Kidney tissue

Aim: Homogenizing

Quantity: 1,5 ml

Approx.time: ca. 40 sec

Unit: HD 2200/3200 with MS 72,
cooling necessary

O/W emulsions

Aim: Finest emulsions

Quantity: 10 ml

Approx.time: ca. 1 min

Unit: HD 3200 with KE 76,

Vessel: rosett cell

Homogenizing of aqueous ink

Aim: Dispersing of ink pigments in oil

Quantity: 200 ml

Approx.time: ca. 5 min

Unit: HD 2200 with VS 70 T

Carbon black dispersions

Aim: Homogenizing

Quantity: 50 ml

Approx.time: ca. 5 min

Unit: HD 2200 with DH 13 G, vessel: KG 3

Accessories and applications

HD 2070 HD 3100

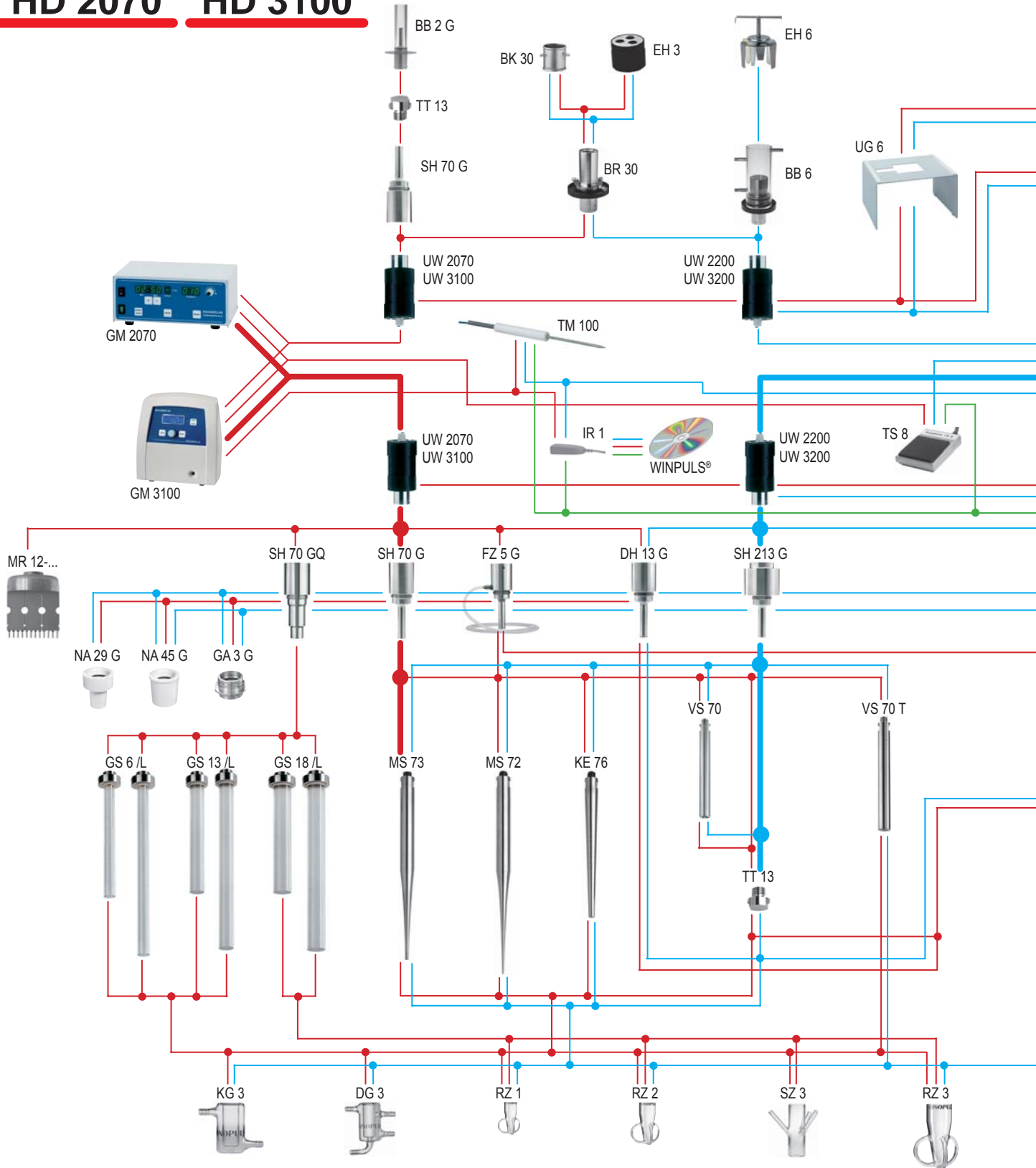

Saccharomyces cerevisiae

Aim: Disruption
Quantity: 20 ml
Approx time: 15 min
Unit: HD 2200/3200 with KE 76, addition of glass beads to accelerate process, cooling necessary

Staphylococcus aureus

Aim: Disruption
Quantity: 10 ml
Approx time: ca. 10 min
Unit: HD 2070/3100 with MS 73

HD 2200 HD 3200

HD 3400

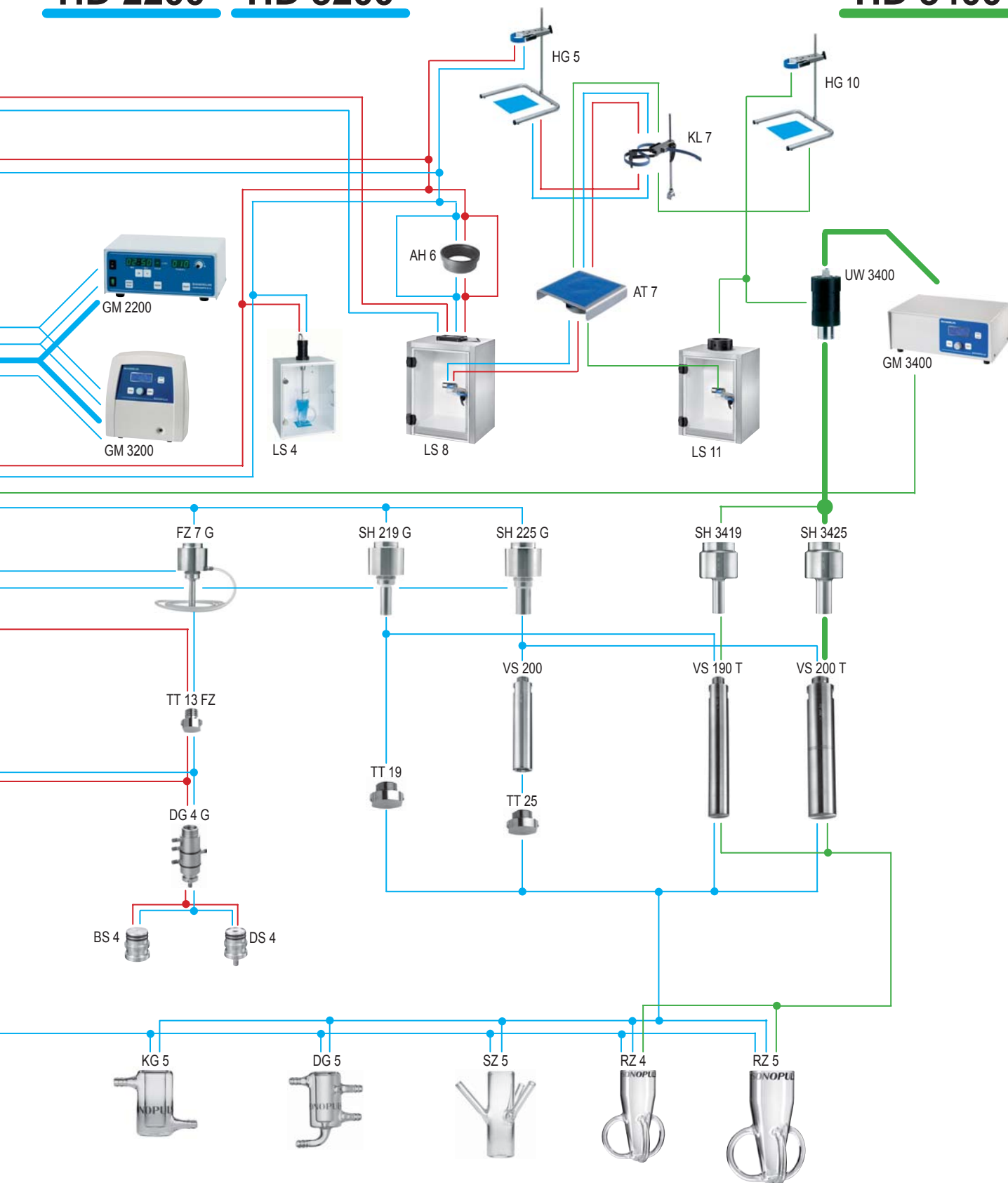

Streptococcus
Aim: Disruption
Quantity: 10 ml
Approx time: ca. 8 - 10 min
Unit: HD 2200/3200 with MS 73

Detection of prions by cyclic amplification of protein misfolding
Quantity: 200 µl
Approx time: ca. 1,5 min
Unit: HD 2070 with MS 73

Other applications on request.

SONOPULS Probes

Probes

made of titanium alloy (Ti-Al6-V4) transmit mechanical longitudinal waves into the sample. They are thermo-resistant, can be treated in autoclaves and are resistant to corrosive media. Sample volume, diameter of the processing vessel and the required amplitude determine the selection of the unit and the type of probe. The higher the amplitude, the more intense the sonication.



Silica glass probes

for connection to HD 2070/3100 with special horn SH 70 GQ. For application in food analysis, pharmacy or environmental analysis. No intrusion of metal particles and boron compounds - ideal for trace analysis. High chemical and temperature shock resistance, no electric conductivity.



SH 70 GQ



GS 13 GS 6

Probe length may vary slightly due to the variations in the titanium material.

Description		Microtips					Tapered tip	Extended probes		
Type		MS 1.5	MS 2.0	MS 2.5	MS 72	MS 73	KE 76	VS 70 T	VS 190 T	VS 200 T
Code No.		3639	3654	3652	492	529	530	494	3638	478
Diameter	mm	1.5	2.0	2.5	2	3	6	13	19	25
Length approx.	mm	57	59	53	191	175	135	130	130	130
Standard horn for HD 2070/3100		-	-	-	SH 70 G	SH 70 G	SH 70 G	SH 70 G	-	-
Booster horn for HD 2200/3200		-	-	-	SH 213 G	SH 213 G	SH 213 G	SH 213 G	SH 219 G SH	SH 225 G
Booster horn for HD 3400		-	-	-	-	-	-	-	3419	SH 3425
Amplitude for HD 2070/3100	µm _{SS}	-	-	-	253 / 285	212 / 245	165 / 191	80 / 97	-	- / -
Amplitude for HD 2200/3200	(peak to peak)	-	-	-	282 / 286	302 / 308	249 / 255	153 / 170	-	46 / 51
Amplitude for HD 3400		-	-	-	-	-	-	-	116	82
Amplitude for mini20		50	70	70	-	-	-	-	-	-
Volume HD 2070/3100	ml	-	-	-	1 – 25	2 – 50	5 – 100	10 – 200	-	-
Volume HD 2200/3200	ml	-	-	-	2 – 30	5 – 90	10 – 350	20 – 900	25 – 900	30 – 1000
Volume HD 3400	ml	-	-	-	-	-	-	-	500 – 1500	500 – 2500
Volume mini20	ml	0.1 – 10	0.25 – 20	0.5 – 25	-	-	-	-	-	-
Vessel diameter (minimum)	mm	4	6	6	4	6	8	17	23	29

Description		Titanteller			Quarzglas-Sonotroden					
Type		TT 13	TT 19	TT 25	GS 6	GS 6 L	GS 13	GS 13 L	GS 18	GS 18 L
Code No.		497	491	532	024	048	028	050	040	054
Diameter	mm	13	19	25	6		13		18	
Length approx	mm	5	5	6	145	290	145	290	145	290
Standard horn for HD 2070/3100		SH 70 G	-	-	SH 70 GQ	-	SH 70 GQ	-	SH 70 GQ	-
Booster horn for HD 2200/3200		SH 213 G	SH 219 G	SH 225 G	-	-	-	-	-	-
Booster horn for HD 3400		-	-	-	-	-	-	-	-	-
Amplitude for HD 2070/3100	µm _{SS}	78 / 93	- / -	- / -	13 / 13	-	13 / 13	-	13 / 13	-
Amplitude for HD 2200/3200	(Spitze-Spitze)	149 / 165	73 / 81	48 / 53	- / -	-	- / -	-	- / -	-
Amplitude for HD 3400		-	-	-	- / -	-	- / -	-	- / -	-
Amplitude for mini20		-	-	-	- / -	-	- / -	-	- / -	-
Volume HD 2070/3100	ml	10 – 200	-	-	2 – 100	-	25 – 200	-	25 – 500	-
Volume HD 2200/3200	ml	20 – 900	25 – 900	30 – 1000	-	-	-	-	-	-
Volume HD 3400	ml	-	-	-	-	-	-	-	-	-
Volume mini20	ml	-	-	-	-	-	-	-	-	-
Vessel diameter (minimum)	mm	17	23	29	10		17		22	

Probe extensions

for enlarging the operating depth when using flat tips.

VS 70 between SH 70 G / 213 G and TT 13

VS 200 between SH 225 G and TT 25



VS 70



VS 200

	probe extensions	
Type	VS 70	VS 200
for HD	2070 / 2200 3100 / 3200	2200 / 3200
Code No.	500	415

Probes • Standard and booster horns • Adapters

Standard and booster horns

(Ti-Al6-V4) are furnished with a thread for replaceable probes. With exterior thread (except SH 3419, SH 3425) to connect various vessels.



Solid standard horn DH 13 G

with diamond coating on the radiating surface; lifetime is thirty times longer than usual.



Flow-through standard and booster horns

material: Ti-6Al-4V, to prepare stable mixtures of non-mixable or hardly mixable liquids (oil-in-water) by direct intrusion of pre-mixed samples into the cavitation field. In combination with flow-through cell DG 4 G, the continuous treatment of 2 different media and parallel tempering is possible.



	standard horn	booster horns					diamond standard horn	flow-through standard horn	flow-through booster horn
Type	SH 70 G	SH 213 G	SH 219 G	SH 225 G	SH 3419	SH 3425	DH 13 G	FZ 5 G	FZ 7 G
for HD	2070 / 3100	2200 / 3200			3400		2070 / 2200 3100 / 3200	2070 / 3100	2200 / 3200
Code No.	486	527	3647	3634	3679	3692	403	490	452

Adapters

Sleeve adapters made of PTFE for tight mounting on standard ground glass vessels.

NA 29 G for NS 29/32 for SH 70/213 G

NA 45 G for NS 45/40 for SH 70/213/219/225G



NA 29 G

NA 45 G

	sleeve adapters	
Type	NA 29 G	NA 45 G
for HD	2070 / 2200 / 3100 / 3200	
Code No.	540	487

MULTISON® ultrasonic probe

patent applied D 10 2004 024 214

for connection to HD 2070/3100.

Composed of Multison horn MRH 12 and 12 Multison tips MRS 2, MRS 3 or MRS 2-2C .

For irradiation of samples in microplates and deep well plates.

Simultaneous sonication of 12 samples. Multison tips individually replaceable.

	Multison probe composed of multison horn with per 1 multison tip			multison tips		
Type	MR 12-2	MR 12-2C	MR 12-3	MRS 2	MRS 3	MRS-2C
Diameter, mm	2	2	3	2	3	2
Length, mm	16					
Code No.	3626	3643	3633	3628	3629	3642



SONOPULS Accessories

Processing vessel, made of stainless steel

DG 4 G for high-volume flow-through processing like emulsifying, dispersing or homogenizing, up to 30 l/h, processing volume approx. 20 ml overpressure < 2 bar flow-through volume 50 l/h The sample can be repeatedly sonicated in circulation. For connection to SH 70 G or SH 213 G with TT 13, DH 13 G.



DG 4 G

	flow-through processing vessel	cooling vessel
Type	DG 4 G	KG 4 G
for HD	2070 / 2200 3100 / 3200	2070 / 2200
Code No.	3608	3608

Processing vessels made of glass

Rosett cell RZ

optimal homogenous and intense circulation of liquids caused by the shape of the vessel and its 3 sidearms

Cooling vessel KG

for sonication of temperature-sensitive samples. The cooling jacket allows circulation of cooling liquid during sonication.

Flow-through vessel DG

with cooling jacket for irradiation of larger volumes. The cooling jacket allows circulation of cooling liquid during sonication.

Suslick cell SZ

with 3 sidearms for introduction of gas or measuring probes.



RZ 3



KG 3

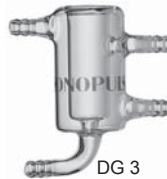

DG 3



SZ 3

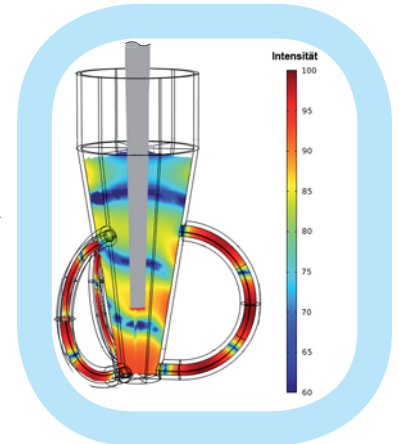

Intensity distribution

(distance between probe tip KE 76 and vessel bottom = 3 cm)

Reference: Beuth Hochschule Berlin

Type	cooling vessels		flow-through vessels		rosett cells					suslick cells	
	KG 3	KG 5	DG 3	DG 5	RZ 1	RZ 2	RZ 3	RZ 4	RZ 5	SZ 3	SZ 5
for HD	2070 / 2200 3100 / 3200	2200 3200	2070 / 2200 3100 / 3200	2070 / 2200	2070 / 2200 / 3100 / 3200			2200 / 3200 3400		2070 3100	2200 3200
volume, ml	15	70	max. 5,6 l/h	max. 30 l/h	25	40	110	390	660	20	110
interior diameter, mm	20	35	20	53	30	42	50	75	90	20	40
height, mm	65	95	65	95	85	100	135	202	243	80	144
Code No.	536	481	538	482	3606	3607	522	3256	483	534	484

Processing vessels for indirect processing

Sonication of smallest samples without any probe intrusion into the sample and no cross-contamination

Cup horn BB 6

The cup horn is equipped with inlet and outlet for circulation of cooling liquid. Also useable for direct sonication. **Microtube holder EH 6** for simultaneous treatment of up to 6 samples can be treated. A mixing of samples is excluded due to markings at the holder.

Cup horn BB 2 G plastics.

Cup booster BR 30

High-intensive irradiation, e. g. radioactive seeds or bacteria as well as for flow-through sonication. The cup booster is equipped with inlet, outlet and overflow. Either cooling or flow-through processing are possible. **Microtube holder EH 3** for simultaneous treatment of up to 3 samples. 2 exchangeable discs with hole diameters 8,5 or 11,5 mm. **Inset basket BK 30** for intensive cleaning of small parts, e. g. cleaning of radioactively contaminated seeds.

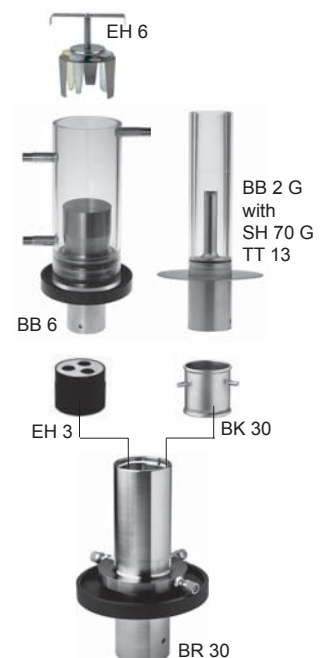

Type	BB 6	BB 2 G	EH 6	BR 30	BK 30	EH 3
for HD	2200 / 3200	2070 / 3100	2200 / 3200	2070 / 2200 3100 / 3200	BR 30	BR 30
Code No.	3605	552	059	082	098	078

Stand

Stainless steel stand

with lab clamp and non-slip mat to hold processing vessels securely in place



Clamping device KL 7 (DE 20 2006 005 654.98)

for HG 5 / HG 10 with rod and swivelling clamp for reaction vessels
dia. 15 mm to dia. 100 mm

Supporting table AT 7

suitable for KL 7 or in LS 8
with non-slip mat to hold
sample vessels securely
in place

Type	HG 5	HG 10	KL 7	AT 7
for HD	2070 / 2200 3100 / 3200	3400	HG 5 HG 10	KL 7 LS 8
Code No.	459	3646	3636	3644

Sound proof boxes

reduce the noise level considerably. Precut holes at the backside allow connections for gas supply and flow-through processing. Acrylic door permits process monitoring.

LS 4 Plastic coated walls, 10 dB-AU damping.

LS 8 made of stainless steel, with damping material. 20 dB-AU damping.

The damping material is water resistant – easy cleaning.

With rod, swivelling clamp and clamp for height adjustment of sample vessels.

Clamping belt for safe fixing of sample vessels with different sizes. Also applicable for sonication of samples in glass vessels with round bottoms or with inlets from below.

Special support UG 6 is available for inverted position of the box during indirect sonication with cup horn BB 6 or cup booster BR 30. Ultrasonic converter is fixed safely through a special clamp.

LS 11 made of stainless steel with damping material, 20 dB-AU damping. The damping material is water resistant, easy cleaning. **Distance tube** for direct processing with long probes.

AH 6 for MS 72/73, KE 76, VS 70 with TT 13,
VS 200 mit TT 25 / VS 200 T, VS 70 T, GS ...

BD 8 damping material for sound proof boxes



LS 4

LS 8



LS 8 with UG 6



LS 11

Type	LS 4	LS 8	LS 11	UG 6	AH 6	BD 8
for HD	2070 / 2200 3100 / 3200	2070 / 2200 3100 / 3200	3400	2070 / 2200 3100 / 3200	LS 8	LS 8 LS 11
dB-AU damping	10	20	20	-	-	-
Code No.	416	3653	3663	3616	3619	3661

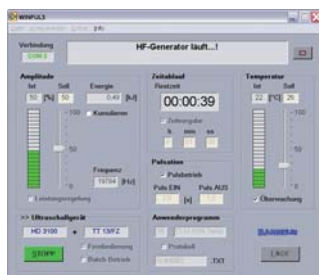

WINPULS® remote control

For process control with PC for operation systems MICROSOFT® WINDOWS® 2000 and MICROSOFT® WINDOWS® XP.

With different additional functions like test logging and comfortable data storage (up to 99 storages). Set composed of WINPULS® software and infrared adapter IR 1 for interface RS 232

Type	WINPULS® software with infrared adapter IR 1
for HD	3100 / 3200 / 3400
Code No.	3625

Foot switch remote control

for easy switching ON/OFF of the HF generator.
With 3 m cable.



TS 8

Type	TS 8
for HD	2070 / 2200 3100 / 3200 / 3400
Code No.	531

Temperature sensor

for measuring the sample temperature
from 0 up to 120 °C.
Sensor diameter: 4 mm



TM 100

Type	TM 100
for HD	3100 / 3200 / 3400
Code No.	3622

VORTEX® reactor

- Intensifying of industrial, biotechnological and chemical processes
- Degassing
- Disrupting of bacteria
- Disinfection of liquids
- Producing of finest polishing pastes for wafer industry
- Homogenizing



WR 4-1503.01

Ready-to-use reactor consisting of:
Vortex reactorbloc WB and HF generator LG 2002 T

Tube reactor SONOBLOC®

- intensive treatment of fibrous and bandshaped products
- Support of industrial and biotechnological processes
- Wire cleaning
- Degassing
- Disrupting of bacteria
- Acceleration of disintegration
- Dispersing of solid particles in liquids



SB 8-1002.01

Ready-to-use tube reactor consisting of:
Tube reactorbloc RB and HF generator LG 1001 T

Technical Data	Vortex reactorbloc - WB			Tube reactorbloc - RB	
	WB 4-1402...	WB 4-1503...	WB 4-1604...	RB 8-1002...	RB 8-1004...
Flow-through rate	1 – 50 l/min			1 – 100 l/min	
Internal pressure, max.	10 bar			10 bar	
Solid particles	< 5 mm			-	
Power density, max.	480 W/l	520 W/l	550 W/l	500 W/l	
Power, max.	1400 W	1500 W	1600 W	1000 W	
Frequency	25 kHz	25 und 40 kHz	40 kHz	25 kHz	40 kHz
Tube material / dimensions	stainless steel AISI 316 Ti / dia. 139.7 × 2.6 mm; dia. 104 × 2 mm			stainless steel AISI 316 Ti / dia. 60.3 × 3.6 mm	
Housing dimensions (l × w × h)	290 × 290 × 642 mm			260 × 150 × 990 mm	
Weight, net	approx. 50 kg			approx. 35 kg	
HF generator (separate)	LG 1510 T	LG 2002 T		LG 1001 T	

Units are equipped with standard victaulic connection. Further connection versions on request.
RB 81-1002.01 with hose- and dust-proof housing – degree of protection IP 65.

Separate documentation on request.

SONOREX TECHNIK industrial ultrasonic units



RM 110 UH

SONOREX TECHNIK modular programme RM is available in 6 standard sizes with 4 versions for cleaning as well as for rinsing. Once the cleaning process is defined, the units can be matched individually:

RM ... UH cleaning unit with ultrasound and heating RM ... U cleaning unit with ultrasound
RM ... H rinsing unit with heating RM ... rinsing unit without ultrasound and heating

Frequency 40 kHz, starting with RM 110 UH alternatively 25 kHz. RM 16 UH to 75 UH, 230 V~, 50/60 Hz, RM 110 UH to 210 UH, 380 to 415 V, 3-phase current~, N, PE, 50/60 Hz, 16 A. Heating 30 to 80 °C (86 to 176 °F). Welded tank, 2 mm stainless steel AISI 316 Ti. Overflow, welded one-piece drain, drip-proof stainless steel housing and a sprinkle tube (from RM 110 UH upwards).

Internal tank dimensions (l x w x d) mm	Capacity litres	Type	Code No.	External dimensions (l x w x h) mm	Drain ball valve	HF output W _{eff}	Heating power W	Current consumption A**	Weight net kg
325 × 275 × 200	13,0	RM 16 UH	8200	365 × 340 × 390	G ½	1 × 300	800	4.8	16.0
480 × 300 × 300	30,0	RM 40 UH	8210	540 × 340 × 500	G ¾	1 × 500	1250	7.7	26.0
580 × 500 × 300	60,0	RM 75 UH	8220	640 × 540 × 530	G ¾	1 × 1000	1950	12.9	42.0
600 × 450 × 450	110,0	RM 110 UH	8230	780 × 550 × 800	G 1	1 × 1000	4800	10.5	72.0
1000 × 500 × 400	160,0	RM 180 UH	8250	1180 × 600 × 800	G 1	2 × 1000	7200	14.8	135.0
750 × 650 × 500	210,0	RM 210 UH	8270	930 × 750 × 800	G 1	2 × 1000	7200	14.8	110.0

**from RM 110 pro phase

Models RM 112 to 212 with round tank corners and oblique bottom. Models ZM 112 to 212 with a separate HF generator, multiple-frequency ultrasound at the bottom and at the side, specification like RM 112.

57820 e/2012-03

All units are CE marked.
Illustrations exemplarily, not to scale

Subject to technical alterations without notice.
Decoration products are not included in delivery.

The general delivery terms apply.

BANDELIN

www.bandelin.com
info@bandelin.com

60 years of experience
in ultrasound

BANDELIN electronic
GmbH & Co. KG

Heinrichstraße 3 – 4 • 12207 Berlin
GERMANY

Phone: +49 30 768800 • Fax: +49 30 7734699